



9701 50th Avenue East • Tacoma, WA 98446-5444  
 Phone: (253) 537-7781 • Fax: (253) 536-1759  
 E-Mail: service@summitwater.org

**OFFICERS:**  
 President: Richard Cook  
 Vice President: Dan Watson  
 Treasurer: Mike Craig  
 Secretary-Manager: Darryl Scott

**TRUSTEES:**  
 Chandler Ellis Bradley Ryker  
 Blaine McKanna Greg Armstrong

## Summit Water & Supply Company's 2014 Annual Meeting Notice & 2013 Consumer Confidence Report

### About Summit Water

We are a member owned, "not-for-profit" corporation, "Group A" water system (State of Washington Department of Health identification #85050V). The services of the corporation are provided to the residence, businesses, public entities and other organizations located in the greater Summit/Waller area of Pierce County. There are approximately 5,100 members. The corporation's articles of incorporation and By-laws along with federal, state and local regulations govern the operation of the company.

The Board of Directors meet twice a month and receives member comments. Summit Water will be glad to provide you additional information about water quality, and you may write, call, e-mail, or drop by at 9701 50th Ave. East, Tacoma, WA. 98446-5444, (253-537-7781), service@summitwater.org. For more information about the health effects of the listed contaminants in the material provided in this report, call the Environmental Protection Agency hotline at (800) 426-4791.

The Annual Meeting of Summit Water & Supply Company is scheduled for 6:00 PM, Tuesday, April 8, 2014. The meeting will be at the Summit Water & Supply Company's main office, located at 9701 50th Ave. E. (approximately four blocks west of Canyon Rd., on 50th Ave. E. - private roadway).

### MEETING AGENDA

Minutes of the 2012 Annual Meeting  
 Treasurer's Report  
 Election of Trustee - Position #7  
 Report on Company Operations

### Voting Status

If you are not on the rolls as the property owner (or legal representative) you cannot vote! If you are a new property owner on the water system, you may wish to contact the office. We can verify the membership records as to the listed property owner. Legal documentation is needed to transfer a membership to the owner's name. This is accomplished by sending Summit Water Co. a copy of any recorded documentation that states the name of the legal owner. The Statutory Warranty Deed is the most often used document. Addressing the Board of Directors and voting on business matters requires that the membership be in your name.

### Water Usage (Decrease)

Water consumed during 2013 decreased by approximately 3.7 percent when compared to the usage in 2012 (11.6% decrease by large use irrigators). The total source water pumped was 419 million gallons for 2013 with an additional 131 million gallons purchased by wholesale agreement with Lakewood Water District. The source water, (what we pumped along with the purchased water), decreased by approximately 13.3% compared to the amount of source water pumped in 2012.

### Membership Growth

Paid-in membership increased by twenty-five (25) users for 2013. Out of the twenty-five new connections, one was a large use irrigation connection while the remaining twenty-four were a mix of small and medium residential connections. There are approximately 5100 paid-in memberships and roughly 6775 active users being served by Summit Water.

### Source Protection

For the past 19 years, Summit Water & Supply has continued its development and implementation of a cross-connection control program. This program meets the state cross-connection control regulations. We continue to work closely with the health department and the property owners in our wellhead areas so that everyone works toward protecting this resource. Prudent chemical application practices and disposal methods, will keep your groundwater resource pristine. If you observe evidence of the dumping or abandonment of potential contaminants, **you should report it immediately to the Tacoma-Pierce County Health Department.**

### Water Quality Monitoring Results

Summit Water collected approximately 240 water samples in 2013 from at the sources and throughout the water system. A certified laboratory conducted the analyses on those samples. The results are on file with the Washington Health Department's Drinking Water Program Office and the EPA.

The testing of the sources of supply for the regulated contaminate substances indicated that the **contaminate levels are below** the Maximum Contaminate Level Goals as established by the EPA.

The items listed below were detected in our water during the 2013 sampling period. All are below the levels allowed by the agencies. Not listed are other potential contaminants that were not detected in any of our tests.

Contaminants	Highest Level Allowed (MCL)	Highest Level Detected	Ideal Goals (MCLG)	Potential Sources of Contaminants
<b>REGULATED AT THE GROUNDWATER SOURCES</b>				
Nitrate	10ppm	2.6ppm	10ppm	Runoff from fertilizer/septic and erosion of natural deposits
<b>REGULATED AT THE DISTRIBUTION SYSTEM</b>				
Total Haloacetic Acids	60ppb	Not Detected	0	By-product of drinking water disinfection
TTHM Potential	80ppb	12.8ppb	0	By-product of drinking water disinfection
Chloroform	N/A	1.5ppb	0	By-product of drinking water disinfection
Bromodichloro-methane	N/A	1.8ppb	0	By-product of drinking water disinfection
Chlorodibromo-methane	N/A	4.5ppb	0	By-product of drinking water disinfection
Bromoform	N/A	5.0ppb	0	By-product of drinking water disinfection
Total Coli form Bacteria	>5% of monthly samples	0.006%	0%	Naturally present in the environment
<b>REGULATED AT THE CONSUMER'S TAP</b>				
Copper	1.3ppm	1.3ppm	1.3	Household plumbing

### Lakewood Water District (through wholesale inter-tie)

The items listed below are the highest levels detected in the Lakewood Water District's water for the monitoring period of January 1st to December 31st, 2013. Not listed are those volatile organic chemicals, synthetic organic chemicals and herbicides that were not detected.

## 2013

	Violation	Unit of Measurement	MCLG	MCL	Potential Source of Contaminant
<b>Microbiological Contaminants</b>					
Total Coliform Bacteria	No	70 samples/monthly	0	0	Naturally present in environment
Fecal Coliform and E.coli	No	70 samples/monthly	0	0	Human/animal fecal waste

	Violation	Highest Level Detected	MCLG	MCL	Potential Source of Contaminant
<b>Inorganic Contaminants</b>					
Nitrate	No	2.3ppm	10ppm	10ppm	Fertilizer runoff; leaching from septic tanks; erosion of natural deposits

	Violation	Highest Level Detected	MCLG	MCL	Potential Source of Contaminant
<b>Volatile Organic Contaminants</b>					
Total Haloacetic Acid	No	8.3ppb	60ppb	60ppb	Byproduct of drinking water disinfection
Trihalomethane Potential	No	14.0ppb	80ppb	80ppb	Byproduct of drinking water disinfection
Chloroform	No	9.0ppb	0	N/A	Byproduct of drinking water disinfection
Bromodichloro-methane	No	3.5ppb	0	N/A	Byproduct of drinking water disinfection
Chlorodibromo-methane	No	2.3ppb	0	N/A	Byproduct of drinking water disinfection
Bromoform	No	Not Detected	0	N/A	Byproduct of drinking water disinfection
Tetrachloroethylene	No	4.9ppb	0	5ppb	Used in textile industry and as a component of dry-cleaning products

For a complete copy of Lakewood Water's CCR, please call the Summit Water office at (253) 537-7781 (or see Lakewood Water's website at <http://www.lakewood-water-dist.org>).

## Summit Water Treasurer Retires

Arlene Parrott, long-time employee, Company Historian and Treasurer for Summit Water & Supply Company, announced that she would be retiring at the end of 2013. Arlene has worked for Summit Water for nearly 50 years, beginning her tenure with the Company in 1964 as an employee and also serving as the Summit Water's Treasurer since 1966. Over the years Arlene has shown time and again her dedication and loyalty to the Company and its membership in the professional, considerate and selfless manner in which she has always represented Summit Water. Mrs. "P", on behalf of the Members, the Board of Directors and employees of Summit Water we want to thank you for helping make Summit Water what it is today.

## The Sources of Your Supply

Summit Water maintains seven (7) well sites with system source water being supplied by six (6) active wells and a wholesale connection with Lakewood Water District. The current wholesale contract allows for maximum transfer of 1.5 million gallons per day. The total water pumped from Summit Water sources was 419 million gallons with an additional 131 million gallons purchased by wholesale agreement with Lakewood Water District. Our source wells have a varying operating depth of 195 to 600 feet. Storage facilities consist of three (3) standpipe tanks and two (2) ground level tanks with a combined storage capacity of approximately 7.0 million gallons. Potable water and fire flow are supplied through approximately 110 miles of water pipe ranging in size from 2 to 16 inches. The system is operated as a gravity fed system, which means water flows in and out of the standpipe tanks to meet system demand as well as maintaining adequate system pressure. The distribution system is divided into five (5) pressure zones ranging from a hydraulic elevation of 595 to 125 feet. Pressure reducing valves (PRV stations) are located throughout the system where distribution pipes cross pressure zone boundaries. PRV stations are used to step-down the pressure on the distribution system as water flows downhill and gains pressure. Although Summit Water operates and maintains PRV stations on the distribution system, these stations are meant to protect water main infrastructure, not private plumbing systems (plumbing beyond the water meter). The Company recommends that individual PRVs be installed on all private plumbing systems located in the lower elevation pressure zones. If you would like to know what pressure zone you are located in or have other questions regarding system operations please give us a call at (253) 537-7781 or email us at [service@summitwater.org](mailto:service@summitwater.org) and we will have the appropriate personnel respond to your request.

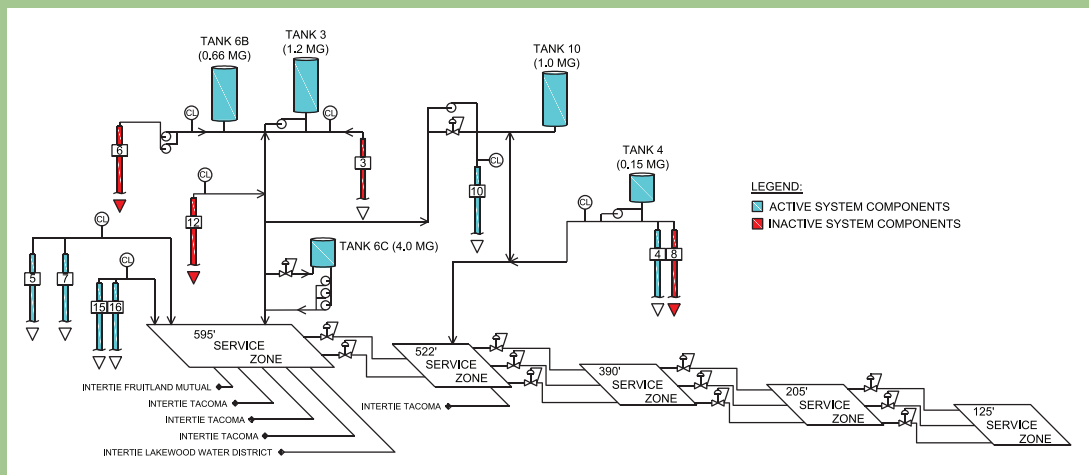

## Water Use Efficiency Program

In January 2008, Summit Water advertised and held a public meeting to establish Water Use Efficiency goals as outlined by the State Health Department. Two of the goals that were set at this meeting were to reduce our Average Daily Demand (ADD) per users by at least 0.5% based on a six-year rolling average and to reduce our distribution system leakage to 10% or less based on a three-year rolling average. Our goal for 2013 was to have reduced our ADD per users to at least 242.1 gallons per day. Our actual ADD per users for 2013 was 226.7 gallons per day, which is well below our established goal. Total water produced/purchased for 2013 was 549,616,279 gallons while metered/accounted for water for the same period was 520,693,667. This resulted in a "Distribution System Leakage" (DSL) or unaccounted for water loss of 5.26% (28,922,612 gallons) for 2013 compared to 10.4% (65,653,314 gallons) for 2012. Based on our average distribution system leakage for 2011 (10.1%), 2012 (10.4%) and 2013 (5.3%) our three-year rolling distribution system leakage average is 8.6%.

## Water Conservation

With Summer approaching quickly, here are some useful websites to help you not only conserve water but save some cash as well. [www.h2ouse.org](http://www.h2ouse.org) • [www.getwise.org](http://www.getwise.org) • [www.americanwater.com](http://www.americanwater.com) • [www.irrigation.org](http://www.irrigation.org)

## Drinking Water Quality

This is the 15th report describing Summit Water & Supply Company's (Summit Water) drinking water sources, quality testing, and programs that protect the quality of the water supply. This publication conforms to a federal regulation requiring water utilities to provide this information annually. The last report was provided to the members and customers in June of 2013. Although the report format may look the same as prior reports there is specific information and statements required by statute. This report covers the year 2013. The report's due date for delivery to every consumer of water delivered by the Summit Water system is July 1 of each year.

The United States Environmental Protection Agency (EPA) and the Washington Health Department's Drinking Water Program Division (DOH) are the agencies responsible for establishing drinking water quality standards. To ensure your tap water is safe to drink, EPA and DOH prescribe regulations stating the allowable limit for specific contaminants the water may contain. We make an effort to balance your "right to know" against the sheer volume of information that we can provide. Our website provides a method to get information out in a cost effective way.

Summit Water goes beyond what is required by these agencies to provide quality water to your home or business, through increased monitoring and placing into practice protection methods that further reduce the risk of contamination.

Water quality monitoring reports are submitted, by Summit and also directly from the testing laboratory, to the DOH who then provides the information to the EPA. The agencies verify our compliance with the many regulatory standards and testing protocols required to assure safe drinking water. **For this reporting period in 2013, the water we provided met the established water quality standards.**

## Safe Drinking Water Hotline

Drinking water, including bottled water, may reasonably be expected to contain at least small amounts of some contaminants. The presence of contaminants does not necessarily indicate that water poses a health risk. More information about contaminants and potential health effects can be obtained by calling the EPA's Hotline **(1-800-426-4791)**.

## Immuno-compromise people

Some people may be more vulnerable to contaminants in drinking water than the general population. Immuno-compromised persons such as persons with cancer undergoing chemotherapy, persons who have undergone organ transplants, people with HIV/AIDS or other immune system disorders, some elderly, and infants can be particularly at risk from infections. These people should seek advice about drinking water from their health care providers. EPA and the federal Centers for Disease Control (CDC) guidelines on appropriate means to lessen the risk of infection by *Cryptosporidium* and other microbial contaminants are available from the EPA's Safe Drinking Water Hotline (1-800-426-4791) between the hours of 6a.m. and 2 p.m. Pacific Time.

## Chlorine Disinfection By-Products

Total Trihalomethanes (TTHM) and Haloacetic Acids (HAA5) are a family of chemicals formed when a disinfectant such as chlorine is added to the water supply. The maximum level permitted for TTHM is 80 parts per billion (ppb) and for HAA5 the maximum level is 60 ppb. Disinfection is an important and necessary step in the supply of tap water, to protect against harmful bacteria and other living organisms that may contaminate the water. Chlorine is the most widely used and approved disinfectant in the United States. Summit Water uses chlorine in a gaseous form, for the disinfection of the water supply. There are no contaminants of the water supply coming from the wells. The primary purpose for chlorine addition is for **potential** contamination of the water distribution system (water mains) up to your meter.

## Important Definitions

**Maximum Contaminant Level (MCL):** The highest level of a contaminant that is allowed in drinking water.

**Maximum Contaminant Level Goal (MCLG):** The level of a contaminant in drinking water below which there is no known or expected risk to health.

**Treatment Technique:** If a contaminant exceeds the maximum contaminant level, EPA may require the water system to use a treatment technique. A treatment technique is a required process intended to reduce the level of a contaminant in drinking water.

## Other Things to Know

Chlorine residuals are maintained throughout the distribution system, and sampling is performed daily to ensure the water has the recommended residual. Certified personnel monitor the chemical addition to the water at the well sites. They also perform on-site tests and collect samples including, but are not limited to, the following:

<b>Daily</b>	Chlorine residuals, pH, and temperature.
<b>Semi-Monthly</b>	Bacteria (total coliform).
<b>Annually</b>	Nitrates.
<b>EPA directed (three year cycle)</b>	Inorganic, volatile organic contaminants, synthetic organic contaminants, radioactivity, lead, copper and Arsenic.

All new construction and repair work performed on the water system infrastructure is treated with chlorine. The water is tested for water purity, by a state approved laboratory, prior to these facilities providing water to you the consumer.

EPA states "The sources of drinking water (both tap water and bottled water) include rivers, lakes, streams, ponds, reservoirs, springs, and wells. As water travels over the surface of the land or through the ground, it dissolves naturally occurring minerals and, in some cases, radioactive material, and can pick up substances resulting from the presence of animals or from human activity."

## Measurements

Water is sampled and tested throughout the year. Contaminants are measured in parts per: million (ppm), billion (ppb), trillion (ppt) and even parts per quadrillion (ppq).

## Additional Water Quality Information

All samples taken at our source wells and throughout our system tested below the minimum levels acceptable to the EPA and the DOH. Wells are also the source of water for the Lakewood Water District (LWD) system. Water purchased from LWD is supplied to Summit Water at a higher level of chlorine residual than what is normally maintained on our system. The blending of the water supplies from the two water systems results in water characteristics, which are not uniform throughout the Summit Water distribution system. This is most noticeable in the Waller Road area.

**Action Levels:** An Action Level is the concentration of a contaminant, which triggers treatment or other requirements, which a water system must follow.

**Part per million; part per billion:** One part per million is the equivalent of 1/2 of a dissolved aspirin tablet in a full bathtub of water (approximately 50 gallons). One part per billion is equivalent to 1/2 of a dissolved aspirin tablet in 1,000 bathtubs of water (approximately 50,000 gallons).

Contaminants that may be present in source water include:

- *Microbial contaminants, such as viruses and bacteria, which may come from sewage treatment plants, septic systems, agricultural livestock operations, and wildlife.*

- *Inorganic contaminants, such as salts and metals, which can be naturally-occurring or result from urban storm water runoff, industrial or domestic wastewater discharges, oil and gas production, mining, or farming.*

- *Pesticides and herbicides, which may come from a variety of sources such as agriculture, urban storm water runoff, and residential uses.*

- *Organic chemical contaminants, including synthetic and volatile organic chemicals, which are byproducts of industrial processes and petroleum production, and can, also come from gas stations, urban storm water runoff, and septic systems.*

- *Radioactive contaminants, which can be naturally occurring or be the result of oil and gas production and mining activities.*

In order to ensure that tap water is safe to drink, EPA prescribes regulations which limit the amount of certain contaminants in water provided by public water systems. Food and Drug Administration regulations establish limits for contaminants in bottled water, which must provide the same protection for public health."