

TYPICAL BLOCKING

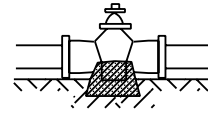

BLOCKING TO BE POURED OPPOSITE VALVES WHICH REDIRECT FLOW OF WATER

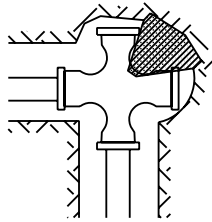
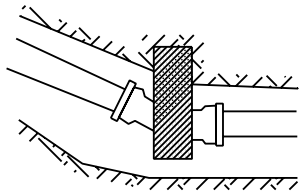
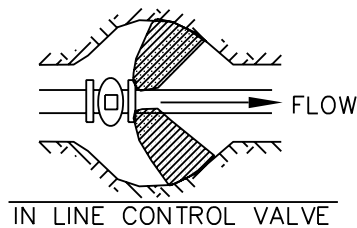
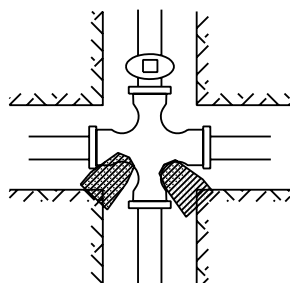
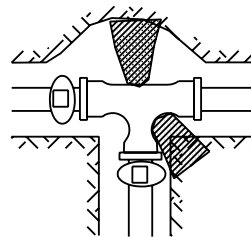
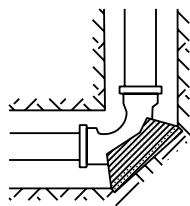
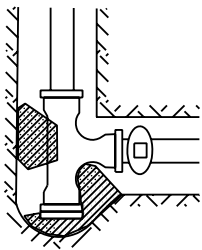
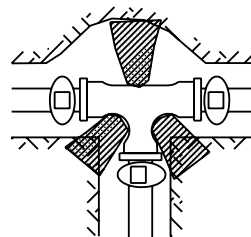
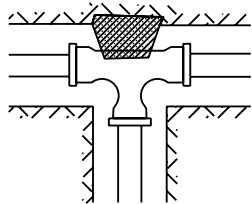
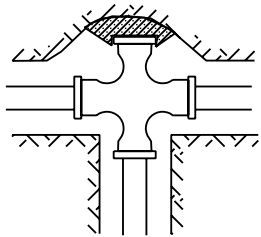

VERTICAL 45° BENDS

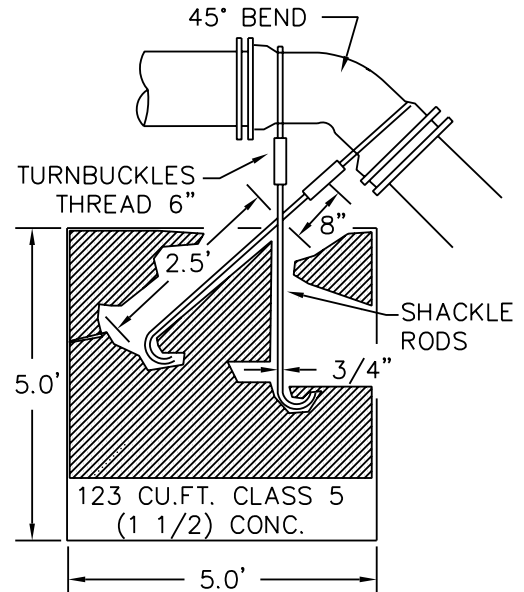

ALL BLOCKING TO BE POURED IN PLACE PORTLAND CEMENT. ALL FITTINGS AND PIPE TO BE WRAPPED WITH PLASTIC FOR PROTECTION. ALL LOOSE MATERIALS TO BE REMOVED TO PROVIDE SUITABLE BACKGROUND TO OUR CONCRETE AGAIN. FOR LARGER CROSSES WITH VALVES (12") A CONCRETE BLOCK WILL BE POURED UNDER THE CENTER OF THE CROSS.